



ERG

Air Pollution Control

AMP8 Odour Control Supply User Guide

www.ergapc.co.uk

ERG (Air Pollution Control) Ltd Bridge House
Lane Five Oaks Road, Slinfold, Horsham
West Sussex, RH13 0QW, UK

Issue 1.2 March 2026

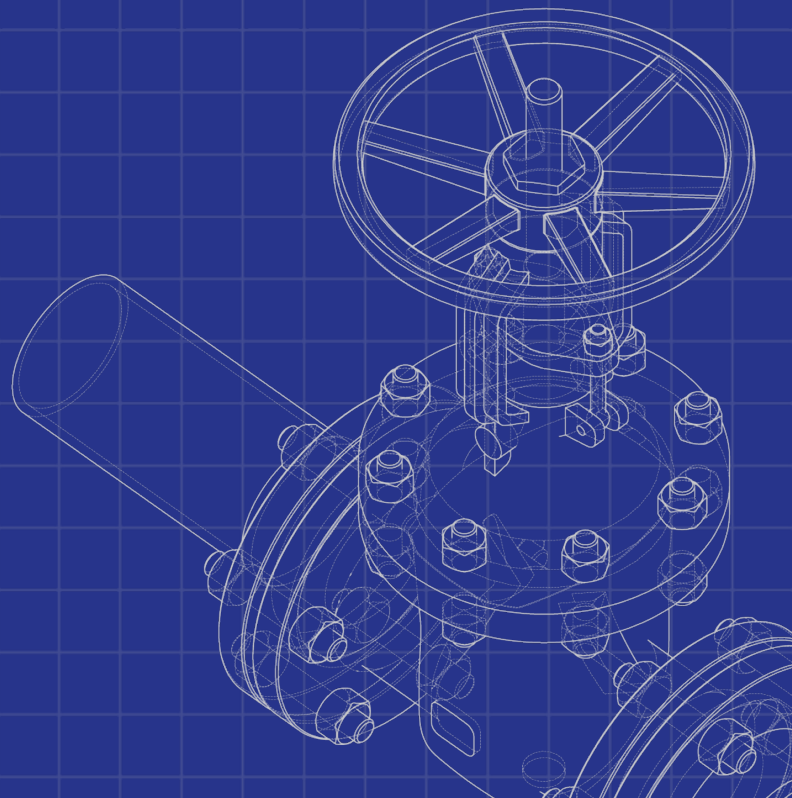

Contents

- 1.0 Scope of Works
- 2.0 ERG Capabilities
- 3.0 ERG Contact Details
- 4.0 Enquiry and Ordering Mechanism
- 5.0 Specifying the Works Odour Control Requirements
- 6.0 Attachments

1.0 Scope of Works

ERG offers a comprehensive range of Odour Control Systems and associated services. The scope of supply ERG offers specifically covers the design, supply, installation, commissioning and maintenance of Odour Control Systems (i.e. ductwork, Odour Control Unit, and associated ancillary equipment) based on:

- Bio-trickling Filters
- Single and dual deep bed Carbon Filters
- Chemical scrubbers, eg for gas conditioning, high ammonia and high mercaptans applications, sludge drying, etc
- Venturi scrubbers for particulate removal.
- Annular Carbon Filters for large air flow rates, eg from cake storage and other low odour building ventilation odour control

Refer to the product literature and range brochures at the end of this user guide. These systems can be offered for the majority of sewage and sludge processing odour control applications.

In addition, ERG is also able to supply the following equipment/systems and services:

- Consultancy in conjunction with AMP8 JV Designers
- Pilot units
- Maintenance services



2.0 ERG Capabilities

2.1 ERG Scope of Works

ERG provides the following comprehensive service:

- Quotation
- Design of the complete Odour Control System
(compliant with relevant Water Company Engineering Specifications and Standards) including:
 - interface with covers and equipment OEMs
 - extraction ductwork and associated supports
 - Odour Control System – Chemical Scrubber, Bio-trickling Filter and/or Carbon Filter and fans
 - control package – MCC/C&I panel, instrumentation, power and control cabling
 - discharge stack and monitoring
 - access structure
- Procurement and manufacture of system equipment items
- Delivery and off-loading
- Mechanical and electrical installation of the system equipment items including site management
- Commissioning and management of performance testing in accordance with relevant Water Company standards and specifications

ERG can offer new-build Capital projects to bespoke designs or from our standard model range, or system upgrades and enhancements for existing plant assets.



2.0 ERG Capabilities

2.2 Design and Implementation

The Design and Project Management documentation includes as a minimum:

- Ductwork and Odour Control Unit P&ID
- Ductwork and odour control unit GA drawings and 3D model (AutoCAD Plant 3D format)
- Civils interface requirements
- Process Control Philosophy and control panel Functional Design Specification (if applicable)
- Process, mechanical and electrical/ICA schedules: equipment, instrumentation, utilities, electrical load, valve/damper, termination point/battery limit schedules
- Electrical SLDs and cable schedule
- Control panel GA/layout and wiring diagrams (if panel is included in ERG scope)
- Key item datasheets
- Quality and Inspection/Test Plan
- Project programme
- Off-loading, installation and commissioning method statements and RAMS
- H&S plan input
- Commissioning plan
- Performance testing protocol and performance testing report
- Operating and maintenance manual, including certified as-built drawings and documentation for the system

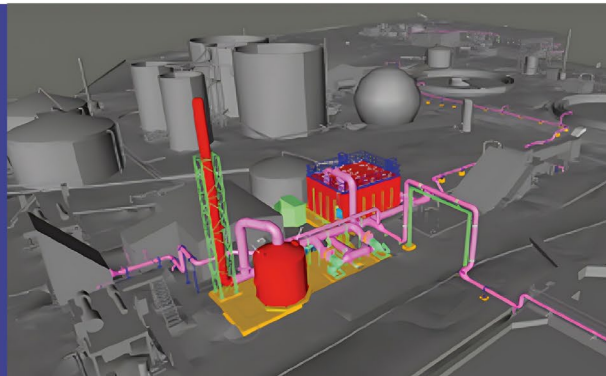

2.0 ERG Capabilities



2.3 Project Management and Site Services

ERG offers the following scope for Project Management and Site Services:

- Dedicated and named Project Manager and Project Design Manager
- Project documentation as above, and appropriate review with the Designer and Project/Site management team
- Procurement, quality control and expediting of all sub-vendor equipment
- Reporting and delivery, installation and commissioning co-ordination throughout the Project
- Management of ERG and sub-contract site labour – all with CSCS cards as a minimum, plus applicable additional skills certification as required
- ERG staff site manager and/or supervisors with SMSTS or SSSTS certification
- Contract management and framework reporting

3.0 ERG Contact Details

ERG's key personnel contact details are:

ERG (Air Pollution Control) Ltd

Bridge House Lane
Five Oaks Road, Horsham
West Sussex
RH13 0QW
Telephone: 01403 290 000
Email: info@ergapc.co.uk
Web: www.ergapc.co.uk

Managing Director

Richard Hanson
Direct 01403 913 058
Mobile 07787 299325
Email richard.hanson@ergapc.co.uk

Framework Manager

Rachel Wood
Mobile +44 7557 366750
Email rachel.wood@ergapc.co.uk

Odour Sales Manager

David Castle
Mobile +44 7385 473664
Email david.castle@ergapc.co.uk

ERG APC Maintenance Ltd

Bridge House Lane
Five Oaks Road, Horsham
West Sussex
RH13 0QW
Telephone: 01403 292 000
Email: info@ergapc.co.uk
Web: www.ergapc.co.uk

Maintenance Director

Troy Gunn
Mobile +44 7799 267247
Email troy.gunn@ergapc.co.uk

Group Sales Director

Damien Connolly
Mobile +44 7436 061594
Email damien.connolly@ergapc.co.uk

4.0 Enquiry and Ordering Mechanism



All enquiry packages for new projects should be sent by email and/or post to ERG's Odour Sales Manager. For maintenance quotations, please contact the Maintenance Director. Contact details for these key staff are found in Section 3 of this User Guide.

The enquiry package should include Works information as described in Section 5 of this User Guide. ERG will provide a compliant offer, together with alternatives as appropriate if there is a whole-life cost benefit.

ERG can then engage in contract negotiations to agree the required scope of works, contract price, payment and contract terms and programme.

5.0 Specifying the Works Odour Control Requirements

In order to provide a Proposal for a new or upgraded Odour Control System, ERG requests the following minimum information:

- Description of the Works
- Odour Control source specification: odour sources including volumes and design extraction rates, concentration and nature of the odour (species, ppm or mg/m concentration and total odour concentration in ou_E^3)
- Required discharge odour concentration
- Required discharge stack height
- Required performance testing level
- Anticipated odour control system scope
- All applicable drawings, with layout of odour sources and location of Odour Control Unit as a minimum
- Site specific technical requirements, e.g. re-use of existing equipment, access limitations, special design considerations, permissible deviations from the water company specifications, availability of final effluent, scope to include control panel and/or electrical installation
- Site specific commercial requirements, e.g. re-use of existing equipment, permissible deviations from the specifications, exceptional H&S requirements, programme requirements
- Site specific construction requirements, e.g. access limitations, exceptional H&S requirements

6.0 Attachments

- ERG's Bio-trickling Filters
- ERG's Carbon Filters
- Bio-trickling Filters product brochure
- Carbon Filter product brochure



ERG's Bio-trickling Filters

Technical Specifications and WIMES Compliant

- ERG's Bio-trickling Filters are fully compliant with the relevant Water Company Standards.
- They are available in cylindrical vessels for smaller air flows and rectangular sectional tanks for larger air flows.
- The treated air can be discharged directly to atmosphere or polished in an ERG Carbon Filter depending on the treatment standard required by the site.
- The Bio-trickling Filters can be designed with different Empty Bed Contact Times (EBCT) but are typically: 20-30 seconds. The tables below relate to 30s EBCT

Cylindrical Vessels

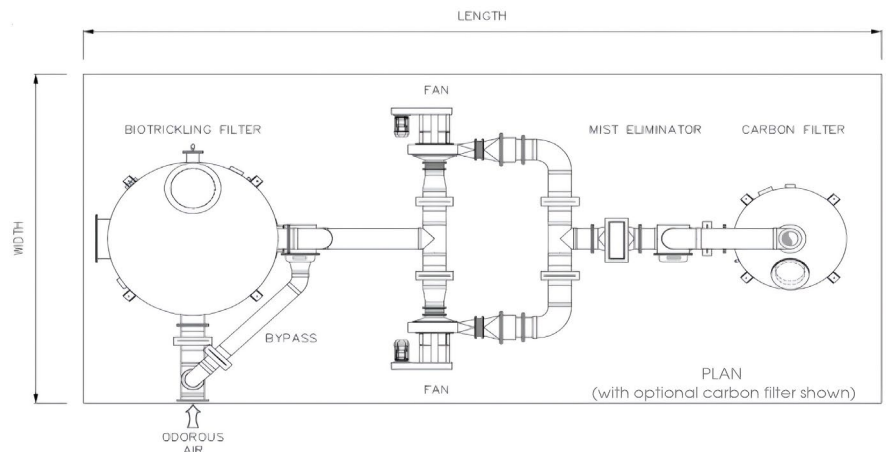
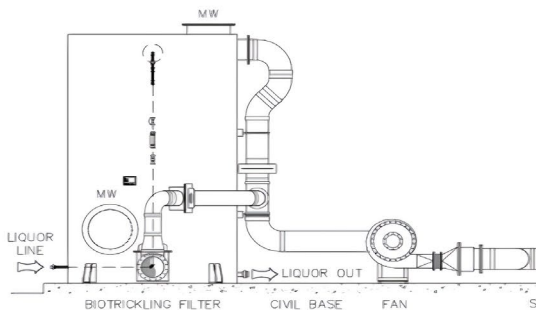

Cylindrical Vessels							
Model No	Air Flowrate Range Am ³ /hr	Bio-trickling Filter Vessel Diameter m	Bio-trickling Filter Height (inc top manway) m	Water Rate m ³ /hr	Media Volume m ³	Footprint (incl carbon filter) length x width m x m	Vessel Weight (full) kg
BTF-C-780-30	100 - 155	0.78	3.7	0.2	0.8 - 1.3	5.0 x 3.0	1,500
BTF-C-950-30	140 - 230	0.95	3.7	0.25	1.2 - 1.9	5.5 x 3.0	1,900
BTF-C-1160-30	220 - 340	1.16	3.7	0.3	1.8 - 2.8	6.0 x 4.0	2,800
BTF-C-1550-30	340 - 600	1.55	3.7	0.45	2.8 - 5.0	7.0 x 4.5	4,600
BTF-C-1910-30	580 - 900	1.91	3.7	0.5	4.8 - 7.5	8.0 x 5.0	6,800
BTF-C-2330-30	850 - 1300	2.33	3.7	1.2	7.1 - 10.8	9.5 x 5.0	9,700
BTF-C-2860-30	1200 - 1925	2.86	3.7	1.9	10.0 - 16.1	10.5 x 5.2	14,200
BTF-C-3100-30	1700 - 2250	3.1	3.7	2.2	14.2 - 18.8	11.0 x 5.7	16,600
BTF-C-3340-30	1900 - 2500	3.34	3.7	2.9	15.9 - 20.9	11.7 x 6.4	18,600

All ERG's Bio-trickling Filters are compliant with the relevant Water Company Specifications and WIMES 8.05.

ERG's Bio-trickling Filters

Rectangular Vessels

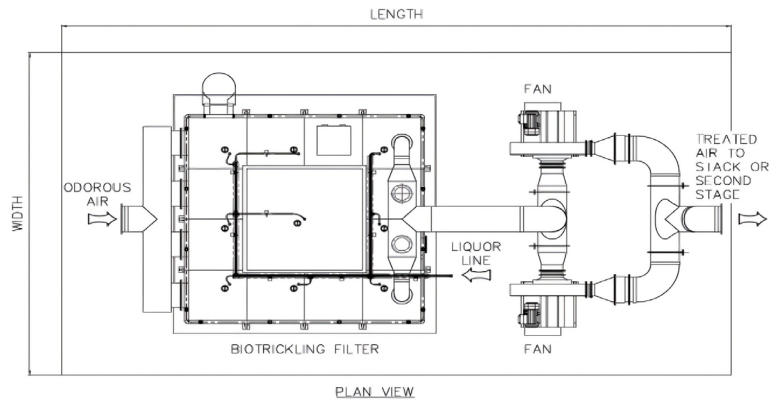
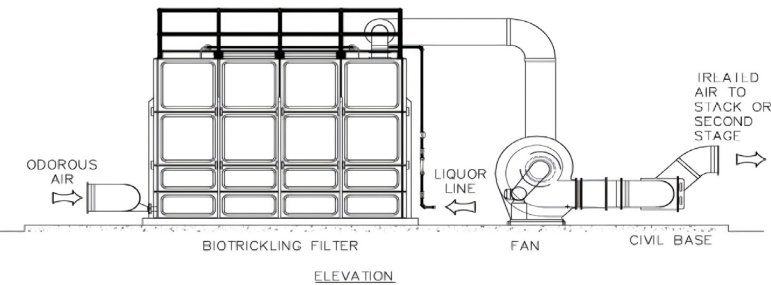

Rectangular Vessels							
Model No	Air Flowrate Range Am /hr	Bio-trickling Filter Vessel Plan Dimensions m	Bio-trickling Filter Height m	Water Rate m /hr	Media Volume m ³	Footprint (incl carbon filter) length x width m x m	Vessel Weight (full) kg
BTF-R-33M-30	2,250 - 3,250	3.0 x 3.0	4	1.8	19 - 27	7.5 x 5.0	21,800
BTF-R-34M-30	3,000 - 4,300	3.0 x 4.0	4	2.4	25 - 36	7.5 x 6.5	27,800
BTF-R-44M-30	4,000 - 5,750	4.0 x 4.0	4	3.2	34 - 48	8.0 x 6.5	36,400
BTF-R-45M-30	5,000 - 7,200	4.0 x 5.0	4	4	42 - 60	11.0 x 6.5	44,900
BTF-R-55M-30	6,250 - 9,000	5.0 x 5.0	4	5	52 - 75	11.0 x 7.0	55,700
BTF-R-56M-30	7,500 - 11,000	5.0 x 6.0	4	6	63 - 90	12.5 x 7.0	66,500
BTF-R-67M-30	10,000 - 15,000	6.0 x 7.0	4	8.4	88 - 126	15.5 x 8.3	92,200
BTF-R-69M-30	13,500 - 19,500	6.0 x 9.0	4	10.8	113 - 162	17.5 x 8.3	117,900
BTF-R-710M-30	17,500 - 25,000	7.0 x 10.0	4	14	147 - 210	18.0 x 10.0	152,000

All ERG's Bio-trickling Filters are compliant with the relevant Water Company Specifications and WIMES 8.05.

ERG's Carbon Filters

Technical Specifications and WIMES Compliant

- ERG's Carbon filters are fully compliant with the relevant Water Company Standards.
- They are available in single or dual bed configurations depending on the air flowrate and odour loading to be treated, and can be provided as a single vessel with bypass or duty/standby vessels if required.
- The Carbon Filter can be used as a stand-alone OCU or as a polishing stage from a Bio-trickling Filter or a Chemical Scrubber depending on the inlet odour loading.
- The Carbon Filters can be designed with different Empty Bed Contact Times which are typically 2 – 3 seconds. The tables below relate to 2.0s EBCT

Single Bed

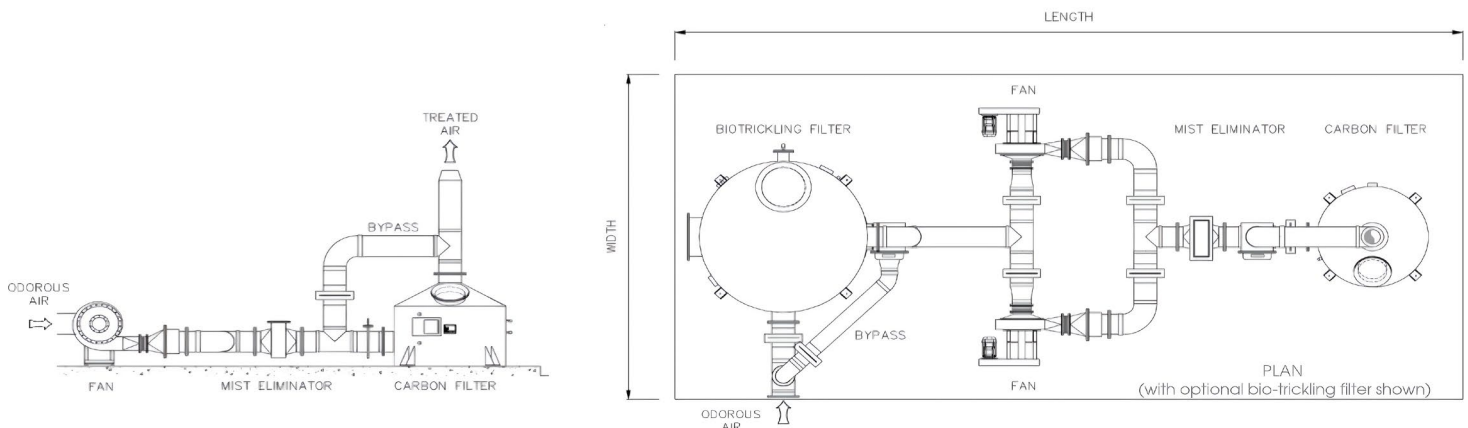

Single Bed						
Model No	Air Flowrate Range (Am ³ /hr)	Carbon Filter Vessel Diameter (m)	Carbon Filter Height (to outlet nozzle) (m)	Media Volume (m ³)	Footprint of Carbon Filter length x width (note 1) (m x m)	Vessel Weight (operating) kg
CF-S-780-2	100 - 500	0.78	1.6	0.1 - 0.3	4.0 x 3.7	300
CF-S-1160-2	500 - 1000	1.16	1.6	0.3 - 0.6	4.5 x 4.3	600
CF-S-1550-2	900 - 1,750	1.55	1.7	0.5 - 1.0	4.7 x 5.3	1000
CF-S-1910-2	1,400 - 2,800	1.91	1.8	0.8 - 1.6	5.2 x 5.7	1600
CF-S-2330-2	2,200 - 4,500	2.33	2.2	1.3 - 2.5	5.7 x 6.7	2200
CF-S-2860-2	3,500 - 7,000	2.86	2.6	2.0 - 3.9	6.7 x 7.7	3500
CF-S-3340-2	5,000 - 10,000	3.1	2.7	2.8 - 5.6	7.5 x 8.7	5000

note 1: dimensions are for duty/standby fans, carbon filter with bypass, and local interconnecting ductwork (excludes upstream bio-trickling filter)

All ERG's Bio-trickling Filters are compliant with the relevant Water Company Specifications and WIMES 8.05.

ERG's Carbon Filters

Dual Deep Bed

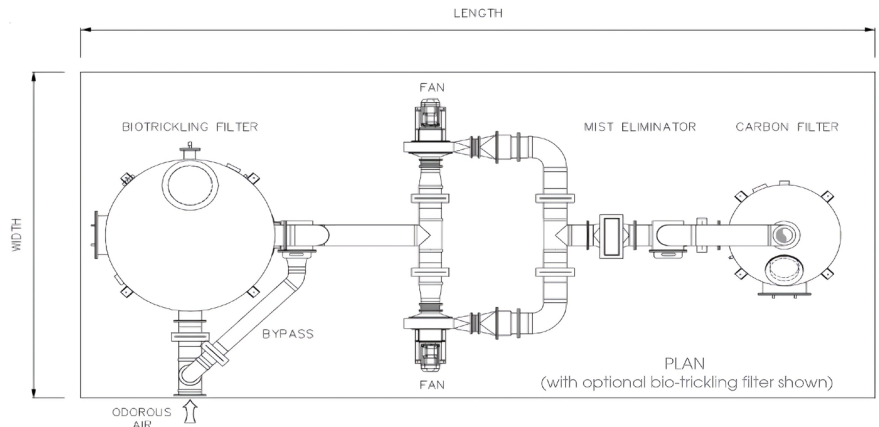
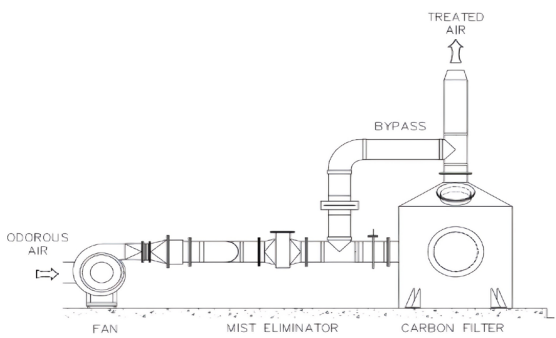

Dual Deep Bed						
Model No	Air Flowrate Range (Am ³ /hr)	Carbon Filter Vessel Diameter (m)	Carbon Filter Height (to outlet nozzle) (m)	Media Volume (m ³)	Footprint of Carbon Filter length x width (note 1) (m x m)	Vessel Weight (operating) kg
CF-D-3100-2	8,000 - 16,000	3.1	3.4	4.5 - 9.0	7.0 x 8.3	8000
CF-D-3880-2	13,000 - 25,000	3.88	3.7	7.3 - 13.9	8.5 x 10.0	12000

note 1: dimensions are for duty/standby fans, Carbon Filter with bypass, and local interconnecting ductwork (excludes upstream Bio-trickling Filter)

Bio-trickling Filters

Sustainable odour control

ERG Bio-trickling Filters provide a high efficiency, sustainable odour control system for small to medium flows. Used as stand-alone packages, or with Dry Media polishing filters, ERG's Bio-trickling Filters provide trouble-free odour control for highly contaminated, small to medium air flowrates (<15,000m³/hr) emanating from waste water treatment processes.

Filled with durable, bio-inert pumice media, they are specifically designed to provide outstanding value for money and simple operation.

ERG has successfully installed over 50 Bio-trickling Filters and Bio-scrubbers in the UK. Performance exceeds 99% H₂S removal efficiency in most cases and, in combination with Carbon Filters, an odour discharge of <1,000 ou_e/m³ is guaranteed and comfortably achieved.

A specifically selected consortium of bacteria, enzymes and nutrients are pre-seeded into the Bio-trickling Filter to ensure there is a rapid development of the odour neutralising bacteria which colonise the pumice bio-media. The bacteria digest the odour-causing compounds, which typically include H₂S, mercaptans, organic sulphides, soluble VOCs and ammonia. The optimised environment for bacterial activity is maintained by controlled irrigation with filtered final effluent, or water dosed with low level nutrients if no final effluent is available.

Designed and built to BS4994 and fully compliant with WIMES 8.05, our Bio-trickling Filter systems offer assured performance and competitive costing.

All our systems are custom-designed for the odour control duty required, and include installation of:

- vessel and biomedium, with optional access structure, non-slip surface and handrails (for walk-on, rectangular vessels)
- irrigation system including strainers, instrumentation and dosing package if required
- air extraction fans and ductwork
- electrical control panel
- downstream carbon filter for enhanced performance



Bio-trickling Filters

Sustainable odour control

Key advantages of ERG's Bio-trickling Filters are:

- All systems are bespoke and designed to match the system requirements.
- The standard range of cylindrical vessels is used for flowrates up to 3,000 m³/hr and modular sectional tanks for flowrates up to 15,000 m³/hr or larger if required.
- The inert pumice stone bio-media lasts for 20 years. The pumice does not decay or suffer from acidification or compaction ensuring contamination removal remains constant for the life of the filter.
- The units are highly compact with a small footprint when compared to woodchip biofilters - they typically use a bed depth up to 4m and residence times of 20 to 30 seconds depending on client specifications.
- They are able to reliably treat high levels of contamination (over 200ppm H₂S) and achieve removal efficiencies of >98% H₂S removal and >95% odour removal in a single tower.
- The operating costs are low when compared with other odour removal technologies.
- The vessels are designed to allow easy maintenance access to the spray nozzles and inspection of the media. Media replacement is achieved using removable hatches.
- The absorption of the contamination (mainly H₂S and sulphurous compounds) into the bio-film around the pumice, and subsequent biological aerobic degradation, forms sulphuric acid effluent which is stable and will not convert back to H₂S when it is released to drain. The Bio-trickling Filter is optimised to ensure an acceptable pH in the effluent stream.
- If filtered final effluent is not available, ERG provide a nutrient dosing system using a proprietary eductor piston dosing pumps (Dosatron® or equivalent).

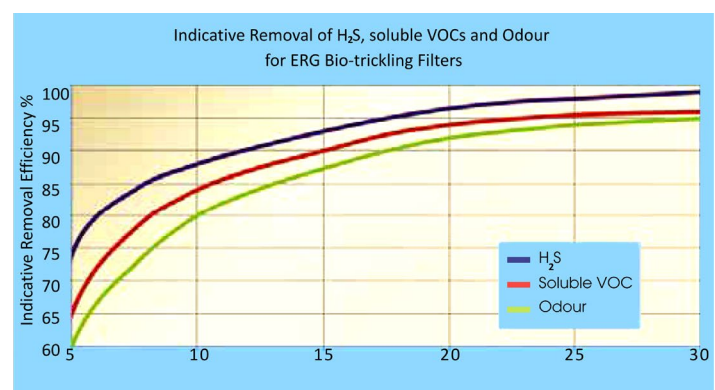
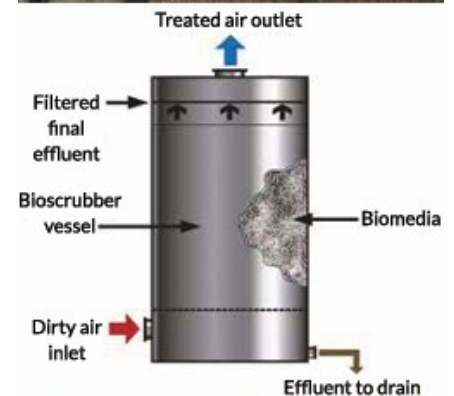

Carbon Filters

Odour control in the Water Industry

ERG offers a comprehensive range of activated carbon, impregnated carbon, oxidising alumina media, and hybrid, multi-media filters. An ERG dry media filter may be used as a standalone filter or for polishing a Bio-trickling Filter or Chemical Scrubber discharge. All our dry media filters require no operator intervention and provide guaranteed odour control performance.

Designed and built to BS4994 and fully compliant with WIMES 8.05, our Carbon Filter systems offer assured performance, guaranteed discharge concentrations and competitive costing.



Key benefits of ERG's range of Carbon Filters:

- High removal efficiency of H₂S and other odours
- Outlet H₂S concentrations <5–10ppb
- VOC polish to <200 ou_E/m³ achieved
- Filters to treat 200 to 200,000 m³/hr
- Low pressure drop <500 Pa
- Bed life designed to suit requirements
- Low capital cost
- Supplied in PVC/GRP or coated steel

Carbon media available through our framework media suppliers Alkali impregnated carbon:

- Pelletised for low pressure drop, up to 25% w/w take-up of H₂S, good mercaptans removal

Activated carbon:

- Pelletised or granular, for VOC removal – virgin or reactivated

Water regenerable carbon:

- Pelletised, up to 20% w/w take-up of H₂S, regenerable using water for up to 20 cycles. Operational cost savings.

Special applications:

- Alternative grades available for unusual duties

Other impregnated media:

- Oxidising media for VOC odour polishing

Performance and system arrangement

ERG has successfully installed over 150 Carbon Filters in the UK. Performance exceeds 99% H₂S and VOC removal efficiency and an odour discharge of <1,000 ou_E/m³ is guaranteed for most applications.

Three filter standard configurations are offered: Deep Bed, Dual Deep Bed and Annular. Bespoke designs are available for special projects.

Carbon Filters

Odour control in the Water Industry

All our systems are custom-designed for the odour control duty required, and include installation of:

- vessel and carbon media, with optional access structure (for walk-on, annular vessels)
- mist eliminator and/or in-duct air heater for moisture conditioning
- air extraction fans and ductwork
- electrical control panel
- integrated system design with upstream Bio-trickling Filters or Chemical Scrubbers

Deep bed filters

- ideal for small to medium air flows 200 to 10,000 m³/hr
- can be passive or forced ventilation
- widely used for local tank ventilation
- single or dual media
- suitable for water regenerable carbon

Dual deep bed filters

- ideal for medium air flows 2,000 to 25,000 m³/hr
- suitable for use as a polishing filter or for bulk removal of odours
- very compact design with small pressure drop
- single or dual media
- suitable for water regenerable carbon

Annular filters

- ideal for medium to large gas flows typically 5,000 to 150,000 m³/hr
- suitable for use as a polishing filter or stand-alone treatment of low odour flows, e.g. sludge cake storage ventilation
- very compact design with small pressure drop

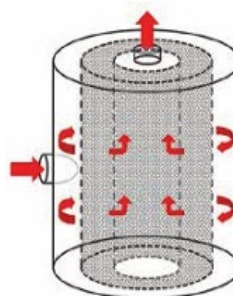
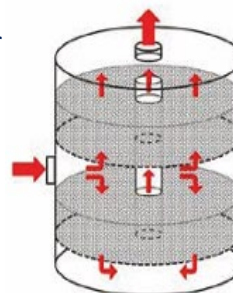
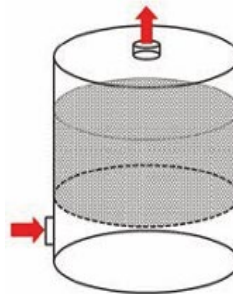



Carbon Filters

Odour Control in the Water Industry

ERG offers a comprehensive range of activated carbon, impregnated carbon, oxidising and hybrid, multi-media filters. An ERG dry media filter may be used as a standard filter or for polishing a Bio-trickling Filter or Chemical Scrubber discharge. All our dry media filters require no operator intervention and provide guaranteed odour control performance.

Designed and built to BS EN 13121-3:2016 and fully compliant with WIMES 8.05, our Carbon Filter systems offer assured performance, guaranteed discharge concentrations and competitive costing.



Key benefits of ERG's range of Carbon Filters

- High removal efficiency of H₂S and other odours
- Outlet H₂S concentrations <5–10ppb
- VOC polish to <200 µg/m³ achieved
- Filters to treat 200 to 200,000 m³/hr
- Low pressure drop <500 Pa
- Bed life designed to suit requirements
- Low capital cost
- Supplied in PVC/GRP or coated steel

Water regenerable carbon

Pelletised, up to 20% w/w take up of H₂S, regenerable using water for up to 20 cycles. Operational cost savings.

Carbon media available Alkali impregnated carbon

Pelletised for low pressure drop, up to 25% w/w take-up of H₂S, good mercaptans removal.

Activated carbon

Pelletised or granular, for VOC removal – virgin or reactivated.

Special applications

Alternative grades available for unusual duties.

Other impregnated media

Oxidising media for VOC odour polishing.

Performance and system arrangement

ERG has successfully installed 100s of Carbon Filters in the UK. Performance exceeds 99% H₂S and VOC removal efficiency and an odour discharge of <1,000 ou/m³ is guaranteed for most applications.

Three standard filter configurations are offered: Deep Bed, Dual Deep Bed and Annular. Bespoke designs are available for special projects.

